

ENCLOSURE PLAN VIEW 1

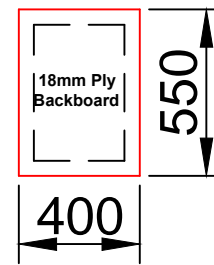

ENCLOSURE REAR VIEW 4

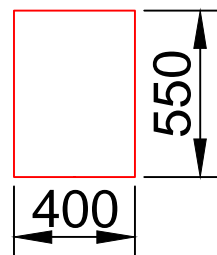

EXTERNAL ELEVATION WALL 2 (SIDE WALL)

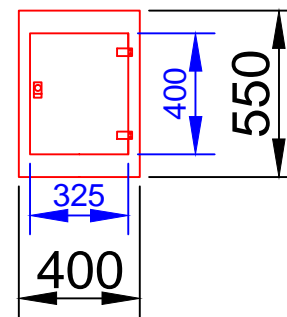

EXTERNAL ELEVATION WALL 1 (FRONT WALL)

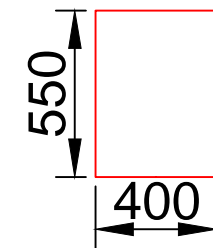

EXTERNAL ELEVATION WALL 3 (SIDE WALL)

Typical Stepped Concrete Base Detail (Recommended)

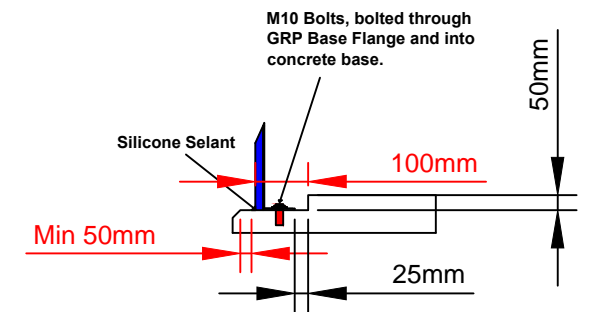

ET1A

OPTIONS LIST

- Any Colour
- 18mm Ply Backboard
- Stainless Steel Hasp & Staple
- Floor: Single Skin
- Vents

Company	The Enclosure Company	External Finish: Semi-Gloss: Smooth	Internal Color: White	External Color: Green (14-C-39)
Contact	Lance Burns	Fire Resistance: BS476 Part 22- 1/2 hr.	Base Flange: 100mm GRP Base Flange	Roof Construction: Single Skin GRP
Order #				
DWG #	ET1A	Doors: 1no. Single Door 325mm x 400mm (H)	Ventilation:	Wall Construction: Single Skin GRP
Rev				
Date	23-06-16			
Scale	N/A			