

**Typical Stepped Concrete Base Detail (Recommended)**

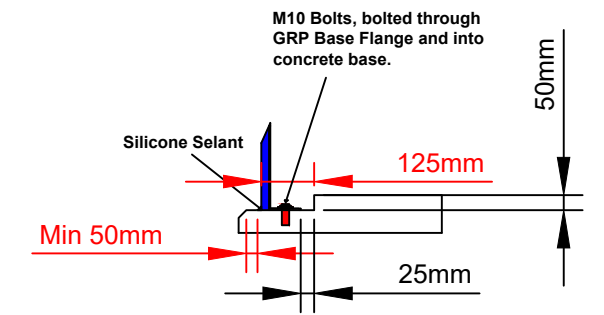

# ET12A

**NOTES:**

**DOUBLE DOOR:**

- 1no. 900mm Wide x 1800mm High
- 4no. Stainless Steel Hinges
- 2no. Stainless Steel Spring Tower Bolts
- 1no. Stainless Steel Hasp & Staple

**BACKBOARD:**

- 1no. 18mm Ply Surface Treated Backboard

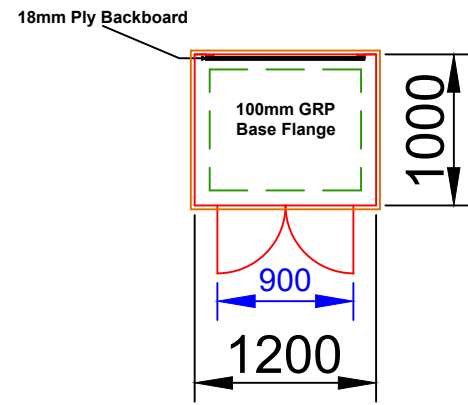

**ENCLOSURE PLAN VIEW 1**

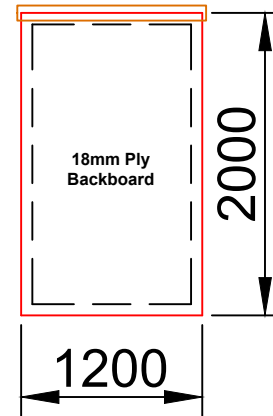

**ENCLOSURE REAR VIEW 4**

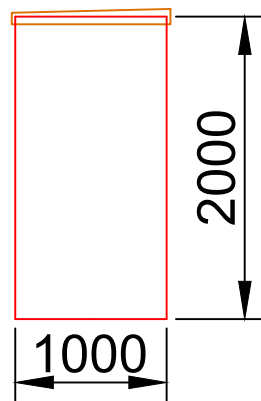

**EXTERNAL ELEVATION WALL 2  
(SIDE WALL)**

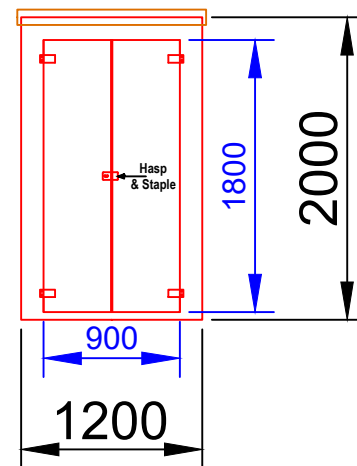

**EXTERNAL ELEVATION WALL 1  
(FRONT WALL)**

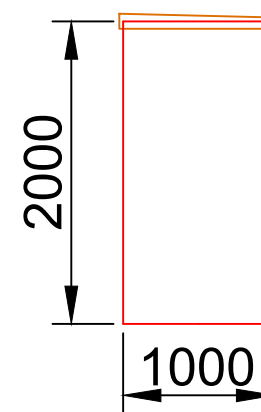

**EXTERNAL ELEVATION WALL 3  
(SIDE WALL)**

Company	The Enclosure Company	External Finish: Semi-Gloss: Smooth	Internal Color: White	External Color: Green (14-C-39)
Contact	Lance Burns	Fire Resistance: BS476 Part 22- 1/2 hr.	Base Flange: 100mm GRP Base Flange	Roof Construction: Single Skin GRP
Order #				
DWG #	ET12A	Doors: 1no. Double Door 900mm x 1800mm (H)	Ventilation:	Wall Construction: Single Skin GRP
Rev				
Date	22-09-16			
Scale	N/A			