

**Typical Stepped Concrete Base Detail (Recommended)**

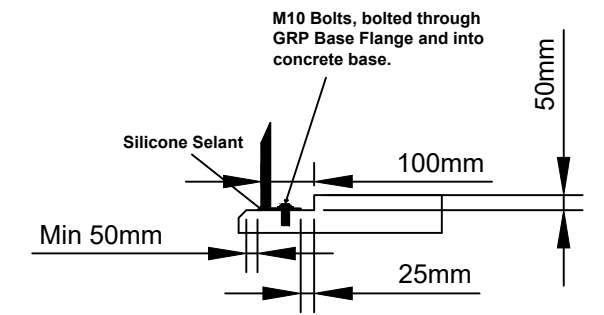

**NOTES:**

- DOUBLE DOOR:**  
 1no. 1730mm Wide x 1300mm High  
 4no. Stainless Steel Hinges  
 2no. Stainless Steel Spring Tower Bolts  
 1no. Cylinder Night Latch Lock or Hasp & Staple

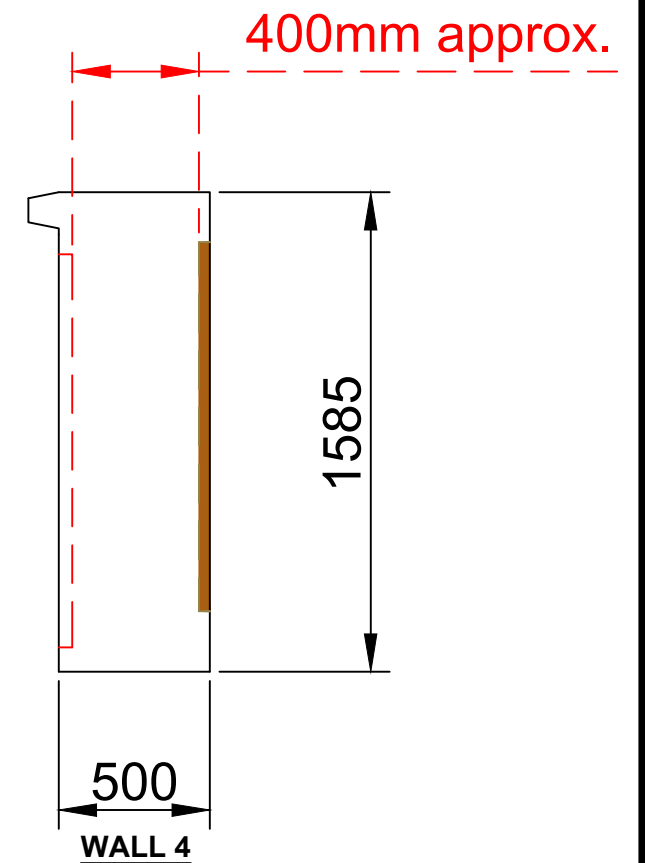
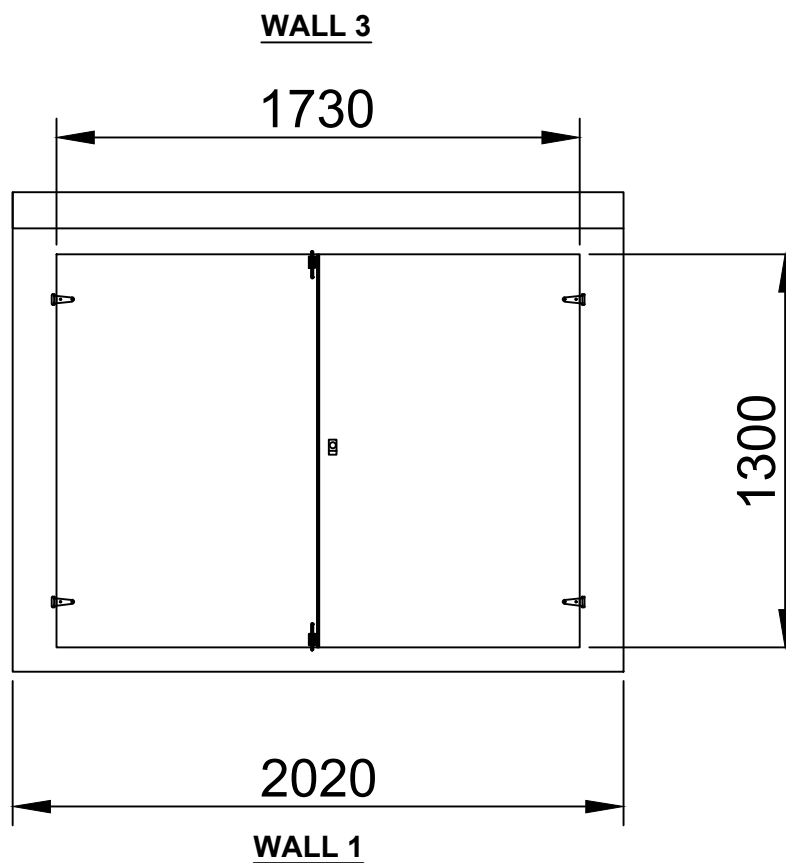
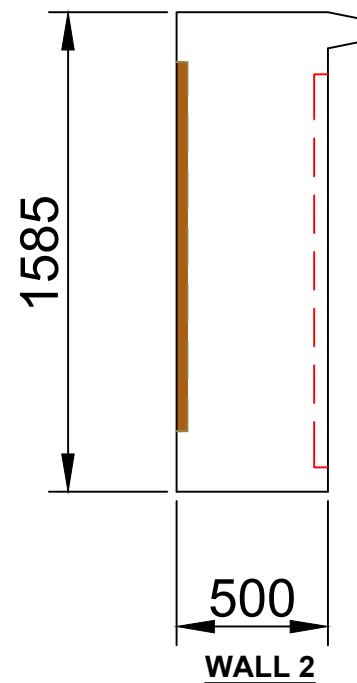

Company	The Enclosure Company	External Finish: Semi Gloss	Internal Color: White	External Color: T.B.C.
Contact	Lance Burns	Fire Resistance: BS476 Part 22- 1/2 hr.	Base Flange: 100mm GRP Base Flange	Roof Construction: GRP
Order #	-			
DWG #	ET11	Doors: 1no. Double Door 1730mm x 1300mm (H)	Ventilation:	Wall Construction: GRP
Rev		Date	28-09-15	Scale
				N/A