

Clear Internal Dimensions - 1850mm x 1850mm x 2000mm

18mm Surface Treated Ply Backboard.

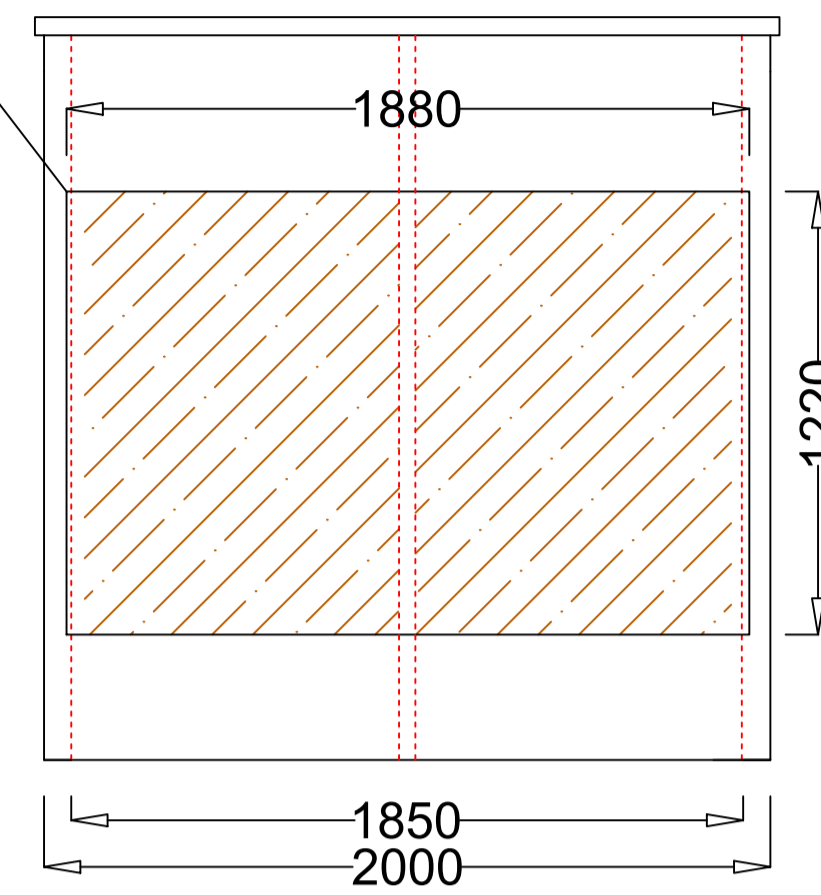

- 1No. Double door (1750 mm W x 1750mm H Clear Opening)
- 4No. St/St Hinges
- 1No. Yale type Lock
- 2No. Shoot Bolts
- 1No. Compression Seal

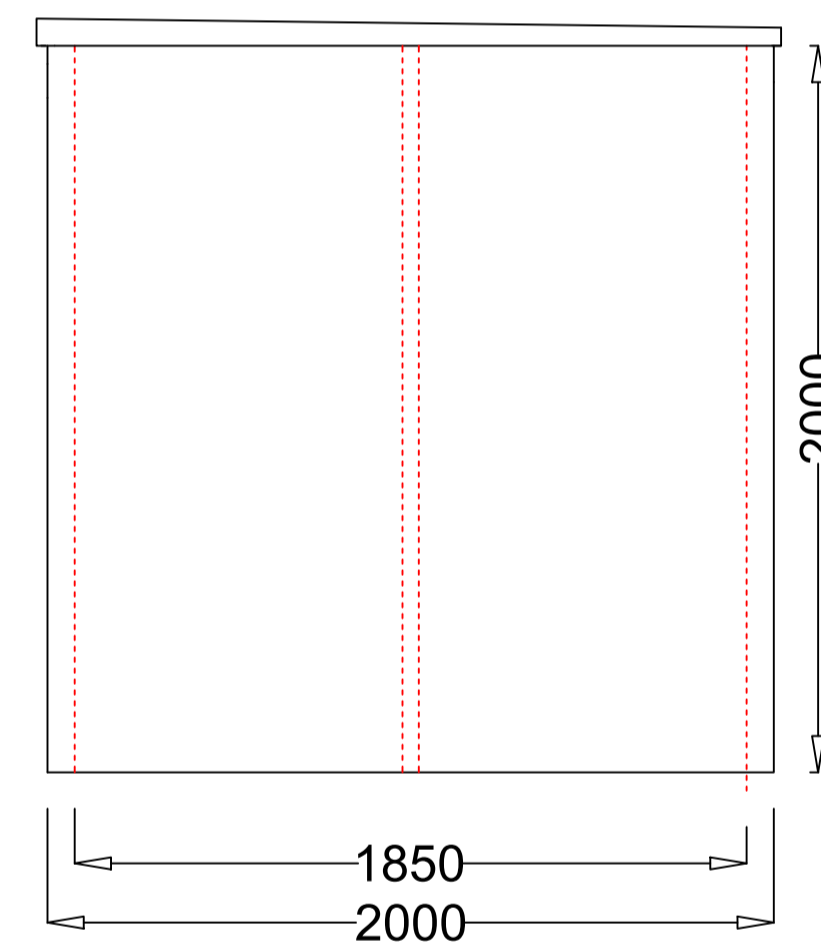
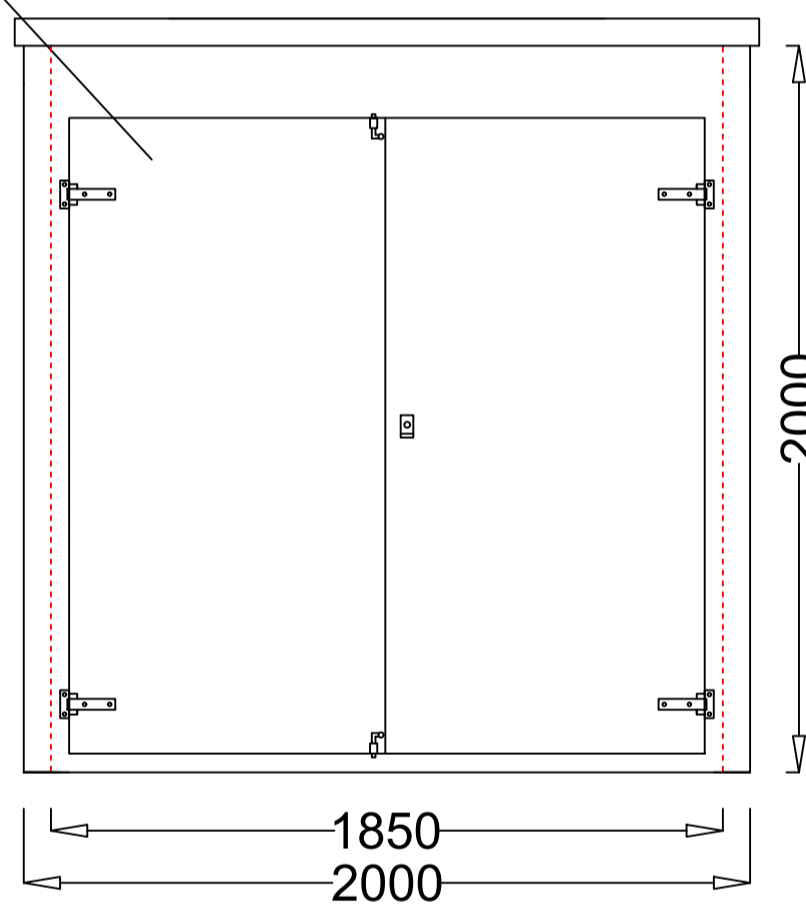
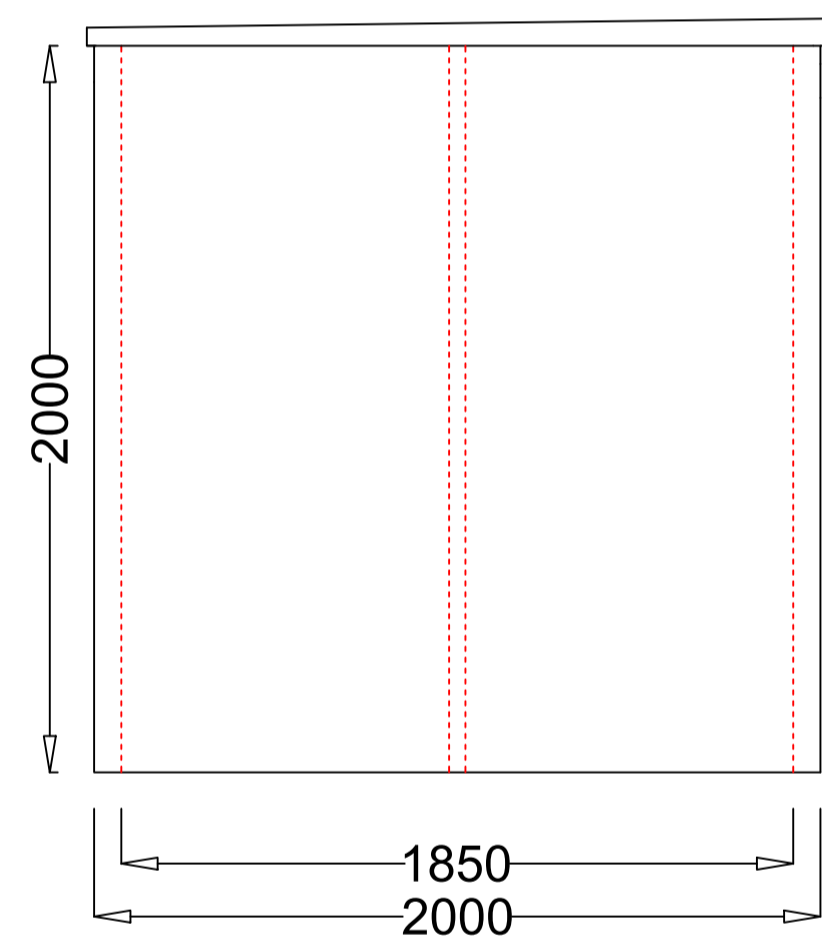

Recommended Base Fixing Detail Plan View

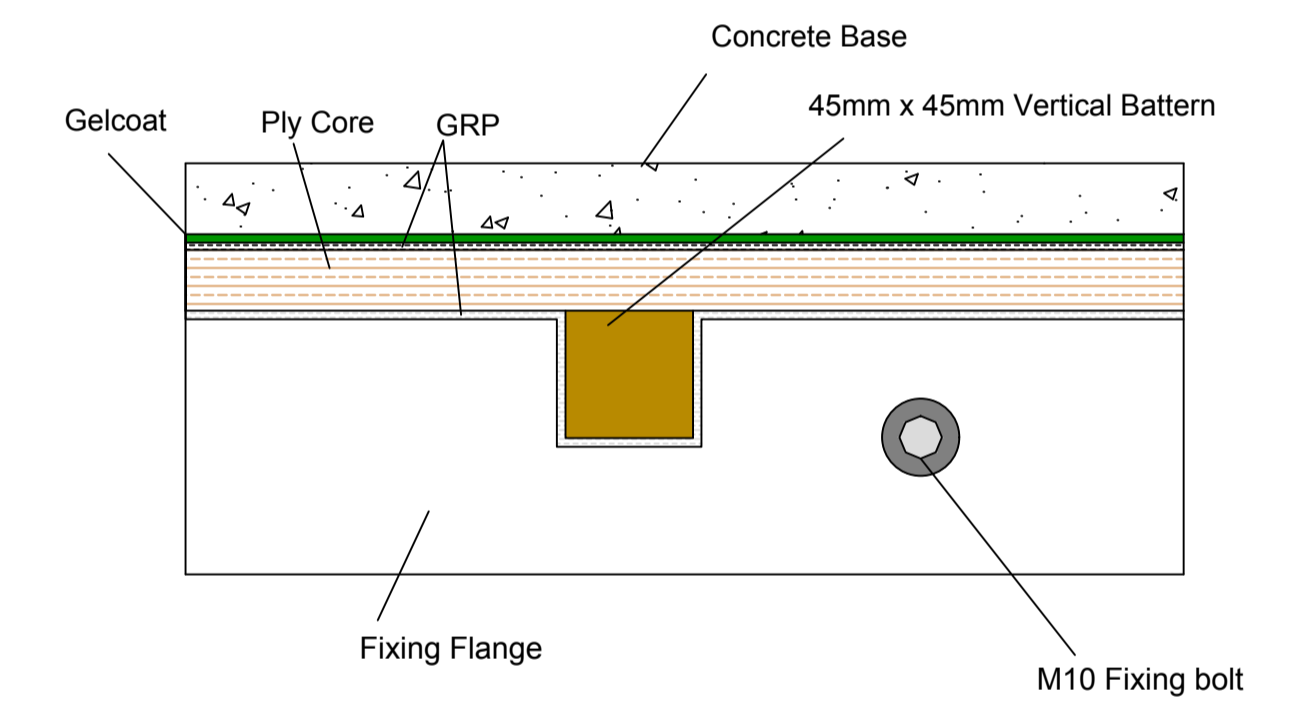

* Fixing Flange to be secured with M10 Bolts at no more than 1 meter Centres

Base Fixing Cross Section

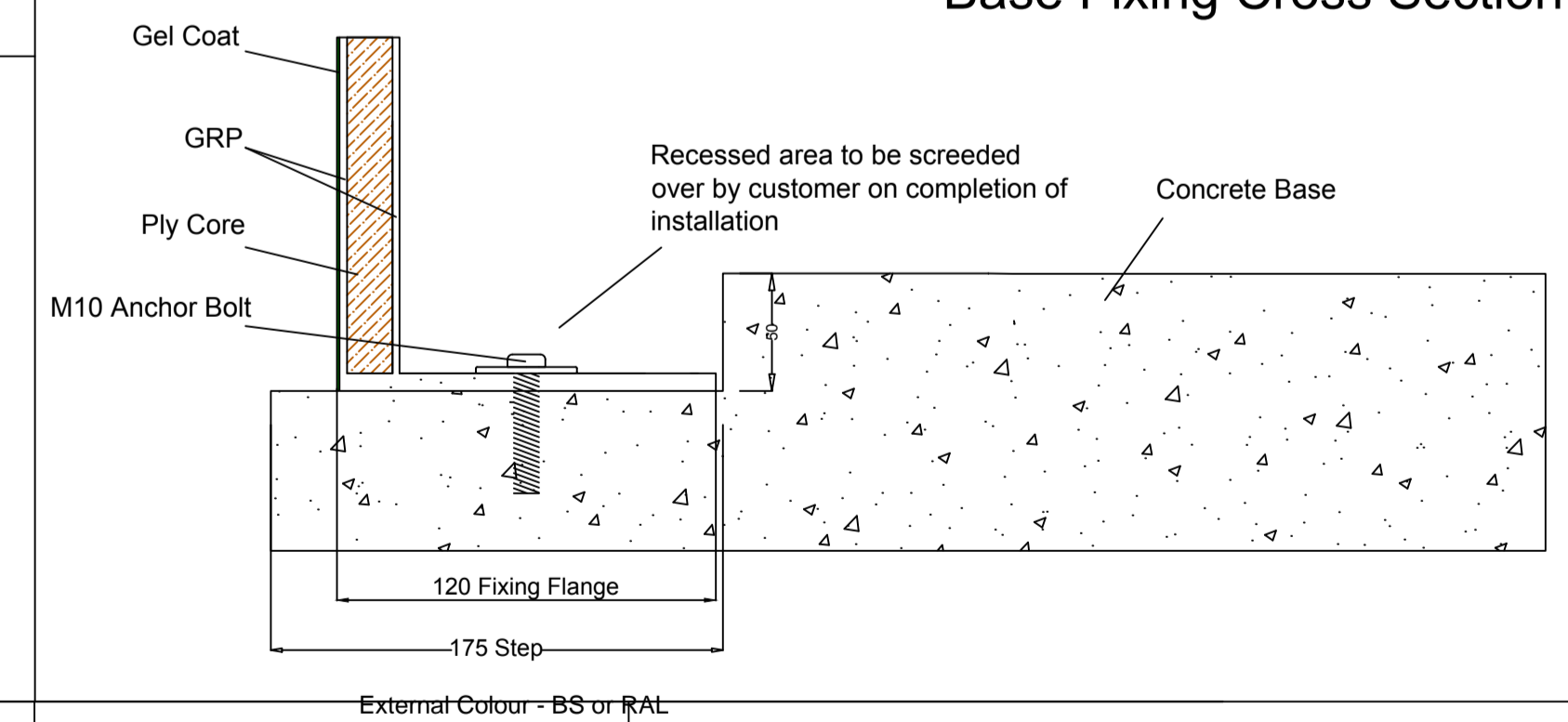

External Colour - BS or RAL

Recommended Stepped Base Detail

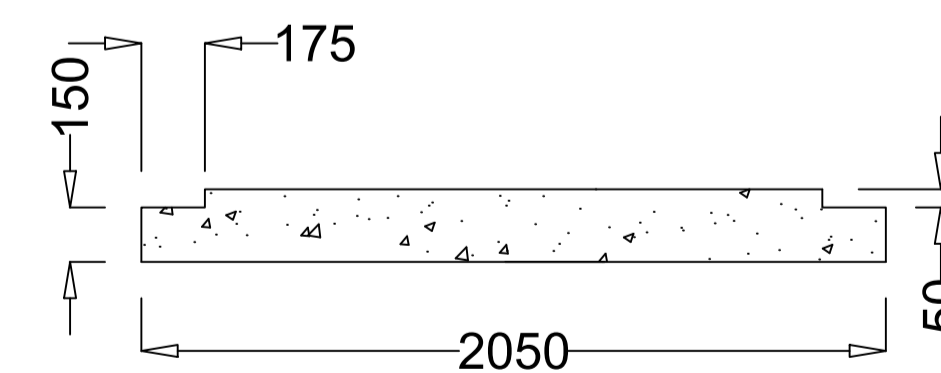
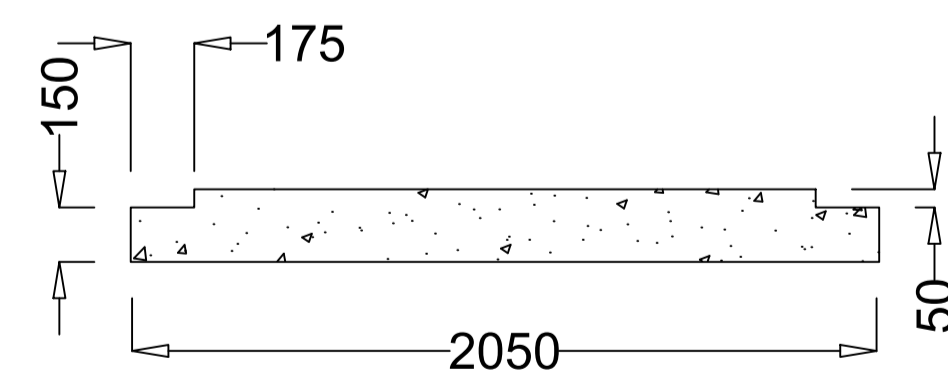
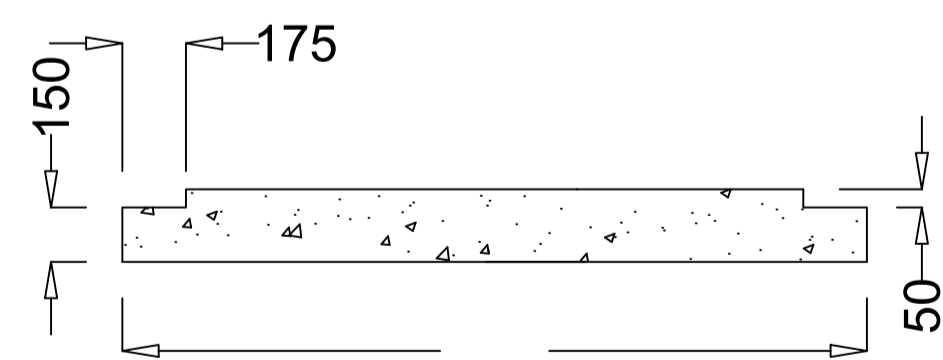

Approx. Weight = 450KG

"U" Value = 2.2 W/sq.m/degC

Wall Construction: 12mm Ply Core & 50mm x 50mm Battens
 Roof Construction: 12mm Ply Core & 50mm x 50mm Battens
 Battens positioned at no more than 1m centres.



GRP Enclosure

+44(0)203 790 7877
 www.grpenclosure.com

Company: GRP Enclosure

Contact: +44(0)203 790 7877

Scheme Title: VR16

Date: 22.06.23

Checked:

Drawing No. VR16