

- Electrics:-**  
 1No. 6 Way S Phase Dist Board  
 1No. Twin Socket c/w RCD  
 1No. 1600mm Twin T8 Light c/w switch  
 1No. 2ft Tubular Heater c/w guard & stat

Clear Internal Dimensions - 1850mm x 1850mm x 2000mm

18mm Surface Treated Ply Backboard.

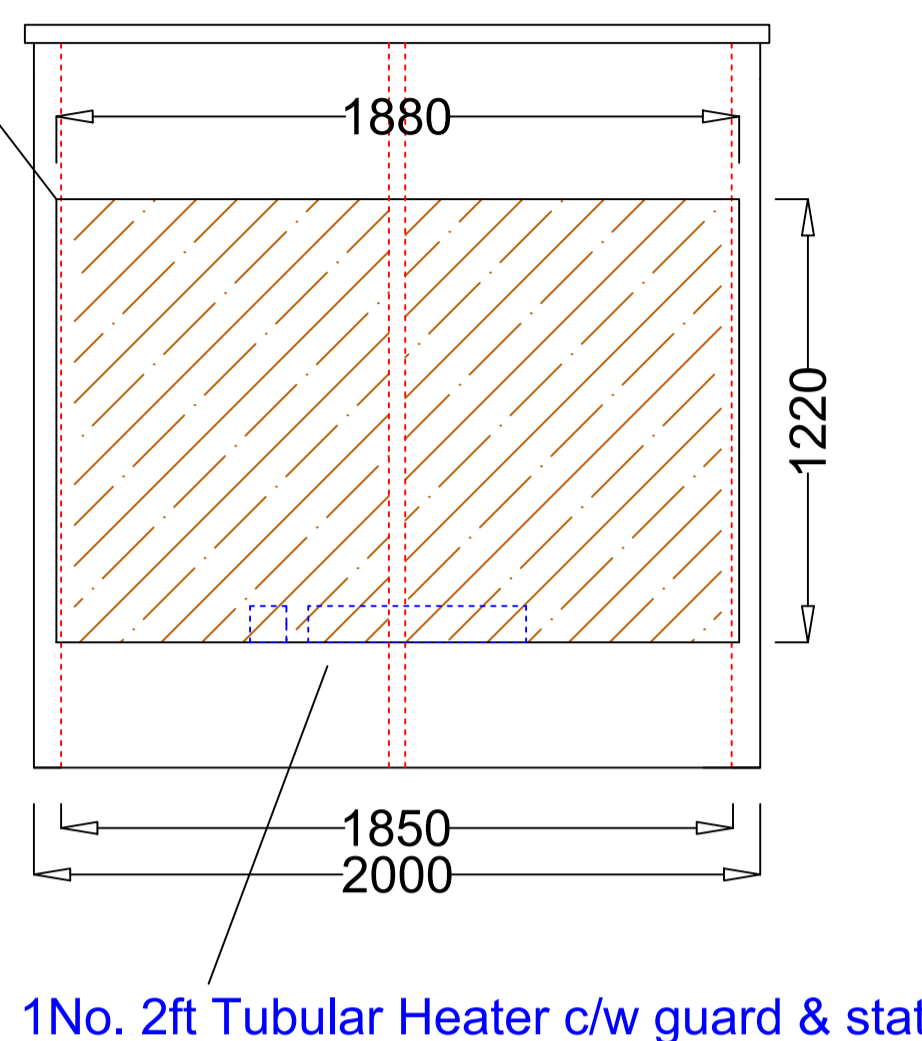

- 1No. Double door (1750 mm W x 1750mm H Clear Opening)  
 4No. St/St Hinges  
 1No. Yale type Lock  
 2No. Shoot Bolts  
 1No. Compression Seal

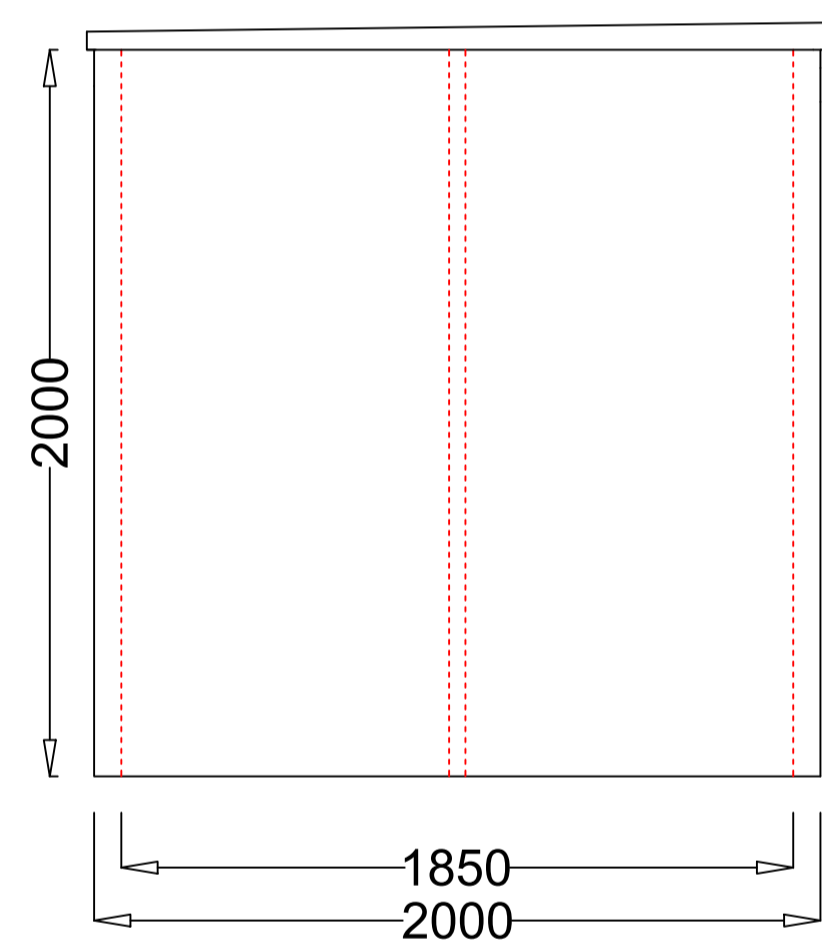

1No. 6 Way S Phase Dist Board

1No. Light Switch

1No. Twin Socket c/w RCD

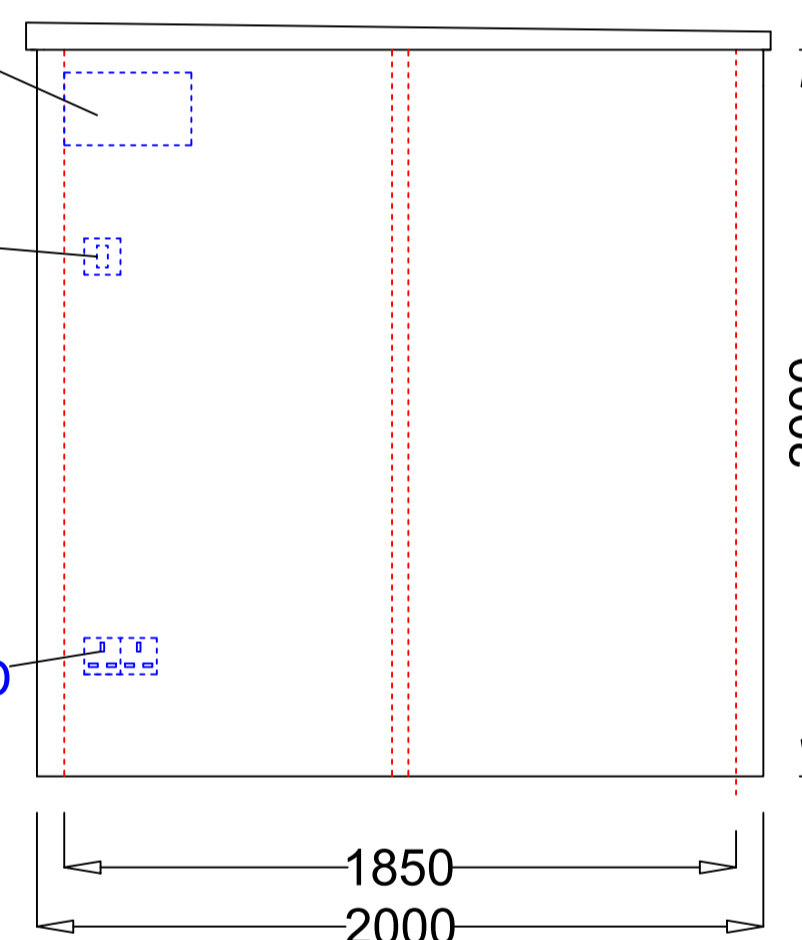
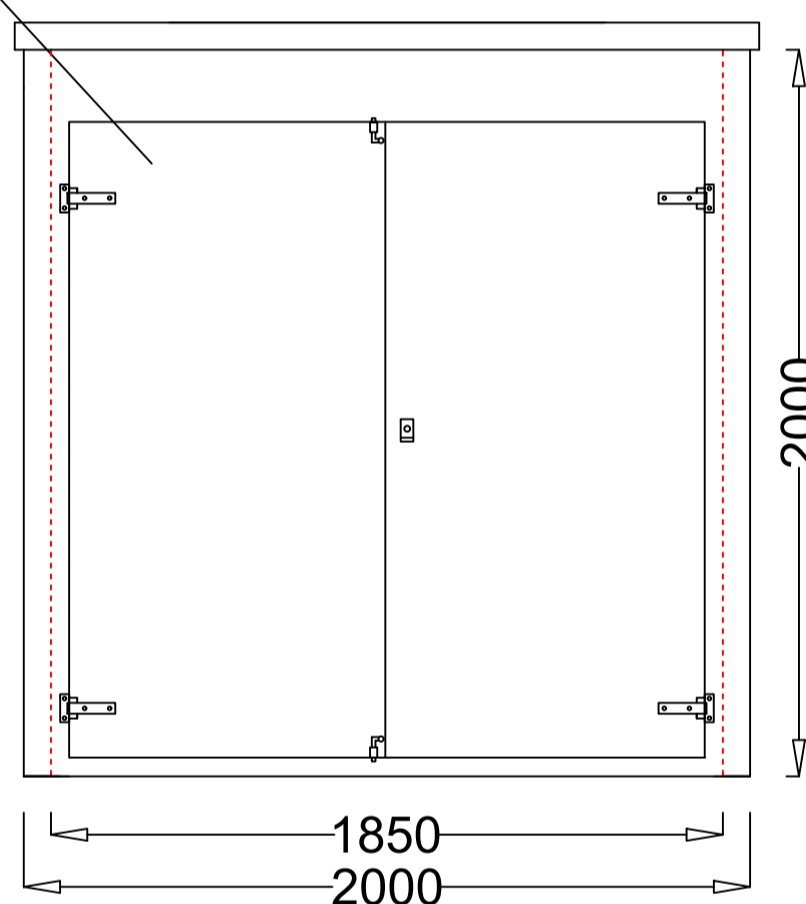

**Recommended Base Fixing Detail Plan View**

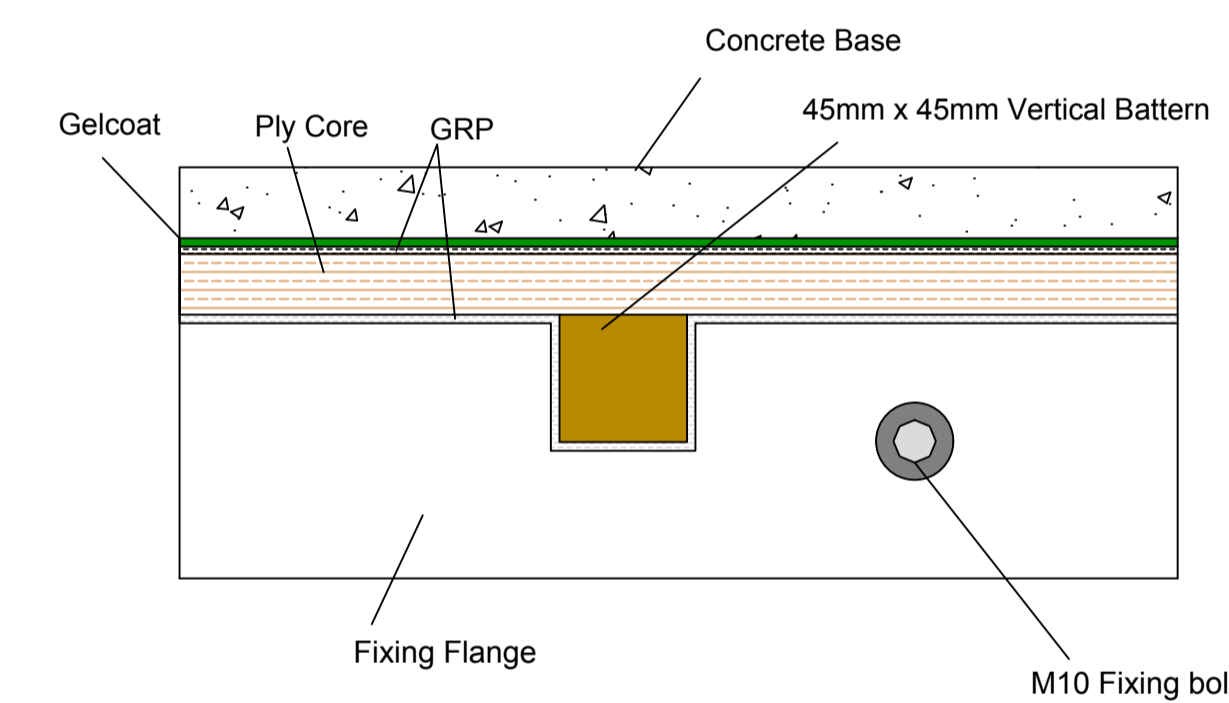

\* Fixing Flange to be secured with M10 Bolts at no more than 1 meter Centres

**Recommended Stepped Base Detail**

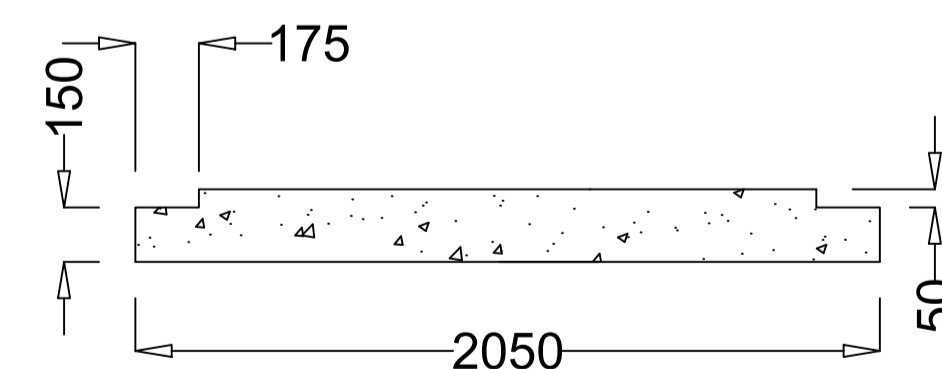
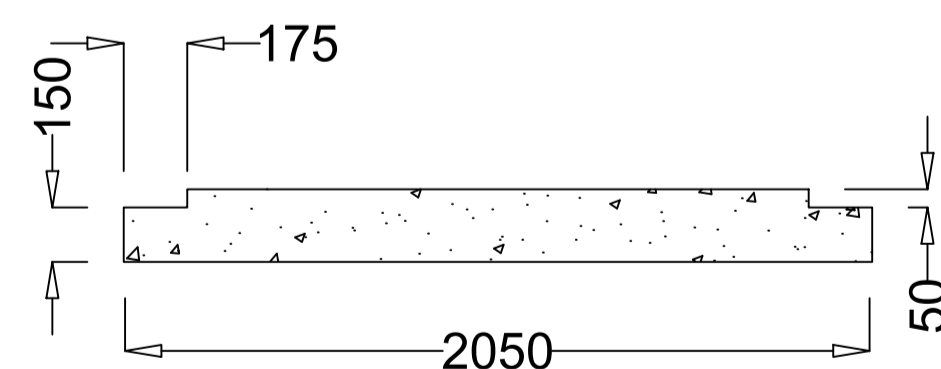
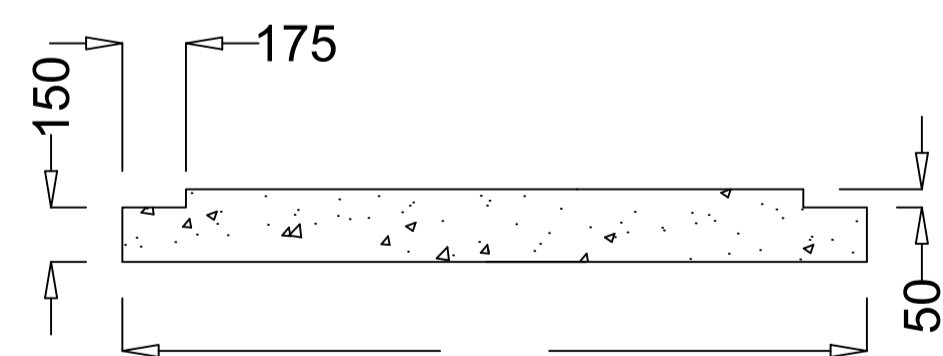

**Base Fixing Cross Section**

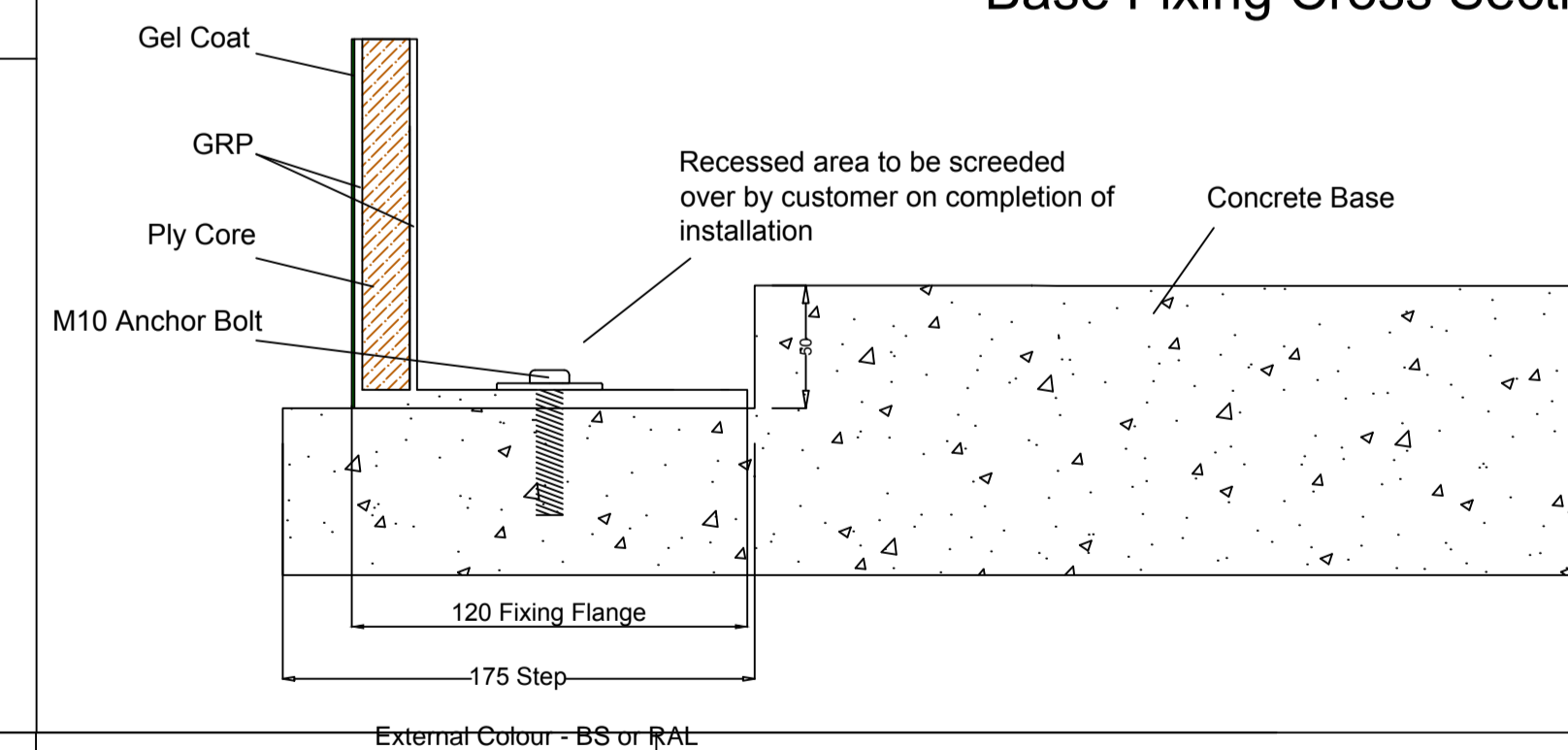

External Colour - BS or RAL

Approx. Weight = 450KG

"U" Value = 2.2 W/sq.m/degC

Wall Construction: 12mm Ply Core & 50mm x 50mm Battens  
 Roof Construction: 12mm Ply Core & 50mm x 50mm Battens  
 Battens positioned at no more than 1m centres.

**Drawing No. VR16-E**



**GRP Enclosure**

+44(0)203 790 7877

www.grpenclosure.com

**Company: GRP Enclosure**

Contact: +44(0)203 790 7877

Scheme Title: VR16-E

**Date: 22.06.23**

Checked: